



**air**  
**cadets**  
*the next generation*

***air cadet publication***  
***ACP 35***

*communications*  
*volume 3 - advanced radio & radar*



Amendment List		Amended by	Date Incorporated
No	Date		
1			
2			
3			
4			
5			
6			
7			
8			
9			
10			
11			
12			
13			
14			
15			
16			

# ACP 35 COMMUNICATIONS

## CONTENTS

Volume 1 .....	Radio Communications (Now ACP 31 Section 6)
Volume 2 .....	Communications Manual (Now ACP 44)
<b>Volume 3 .....</b>	<b>Advanced Radio and Radar</b>
Volume 4 .....	Satellite Communications

### Volume 3

# Advanced Radio and Radar

---

Chapter 1 .....	Communicating
Chapter 2 .....	Receivers
Chapter 3 .....	Radar
Chapter 4 .....	Equipments
Chapter 5 .....	Instructors Guide



# CHAPTER 1

## COMMUNICATING

### Exchange of Information

#### *Exchange of Information*

1. Communication may be defined as the "exchange of information" and as such is a two-way process. Speech is one of the simplest methods of communication there is – and as you know, to use it effectively you need your voice to "transmit" a message (in the form of sound energy) and your ears to receive the reply. Notice that for 2-way communications, each person needs both a method of transmitting information and a method of receiving it.

#### *Speed of Sound Air as a medium*

2. However, using sound does have some drawbacks:
- Speed of travel is quite slow at 300 m/s (the speed of sound).
  - Sound will not travel through a vacuum – it needs a "medium" (normally air) to transmit the energy.
  - Sound does not travel very far, even if you have a loud voice.
  - The sound can be distorted by outside factors such as echoes, wind and other unwanted noises.

**Fig 1-1:** Communicating through string



3. You can improve the way sound travels by replacing air with a solid material. The string in the example carries the sound much better than air – you can speak quietly into one can, and the person holding the other one against an ear can hear you easily. And we all know the old Red Indian trick of putting one ear to the ground to detect the sounds of distant horsemen!

#### *Radio – uses a different energy*

4. While sound works well over short distances, for long-range communications an alternative method must be used – radio. A radio communications system consists

of a transmitter (Tx), to send the message and a receiver (Rx) to receive the reply. The link between the Tx and Rx is this time not sound energy, but electromagnetic (em) energy, - radio waves. Just like light from the sun, radio waves can travel not only through air, but also through a vacuum – and they travel at the same extremely high speed.

**Electromagnetic  
– ‘em’ energy**

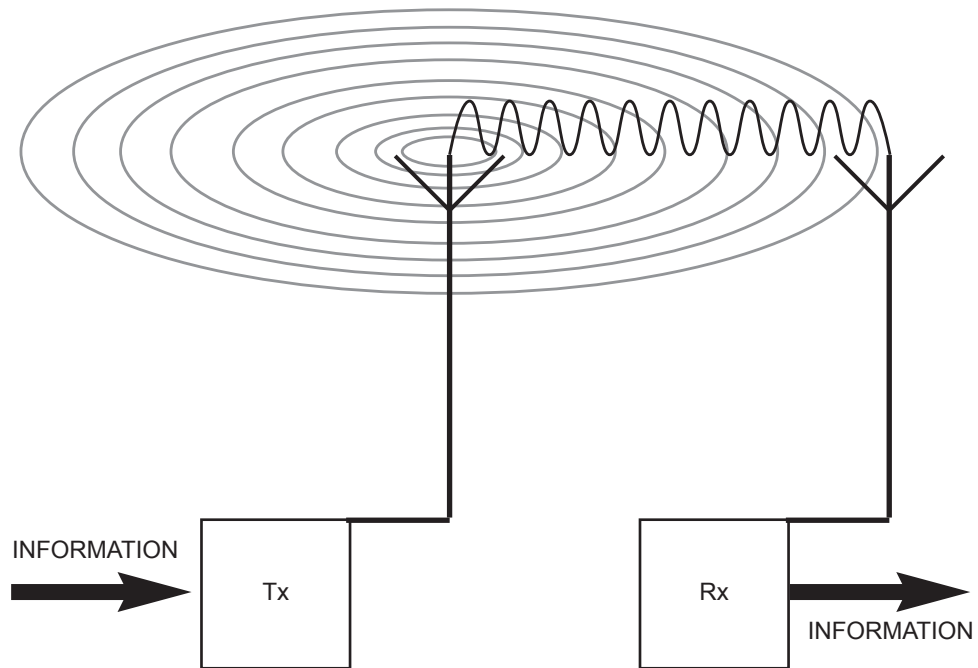

**Fig 1-2:** From transmitter to receiver

5. The job of the transmitter is to convert information into ‘em’ radiation. The information may be sound, TV pictures or digital codes similar to those used by computers. The ‘em’ radiation from the transmitter will then travel in all directions from the aerial. The receiver picks up this signal and converts the ‘em’ radiation back into information.

6. Transmitters come in all shapes and sizes. Your television remote control is one, and so is that for the car alarm. Such devices will have a very small power output of about 50 milliwatts. A television or a radio transmitter will, on the other hand, have a power rating of up to 500 kilowatts. These very high-powered equipments are needed to make transmissions reach to all parts of the country.

What is 'em'?

### What is electromagnetic energy?

7. When an alternating electric current flows in a wire, both magnetic and electric fields are produced outside the wire. It is the combination of these two fields that form 'em' waves. Some can be used for radio communications – radio waves. The frequency of the alternating current will determine the frequency of the 'em' waves produced, and its power rating will govern the range of radiation. There is no theoretical limit to the frequency of 'em' waves, and the expression "electromagnetic spectrum" has been coined to embrace all radiations of this type, which include heat and light.

### Frequency and Wavelength

8. Electromagnetic radiation travels in waves in a similar fashion to sound waves travelling through air. The waves travel in all directions from their source rather like the pattern produced when a stone is dropped into the water in a still pond. A typical wave is usually represented like this:

**Fig 1-3:** A typical waveform

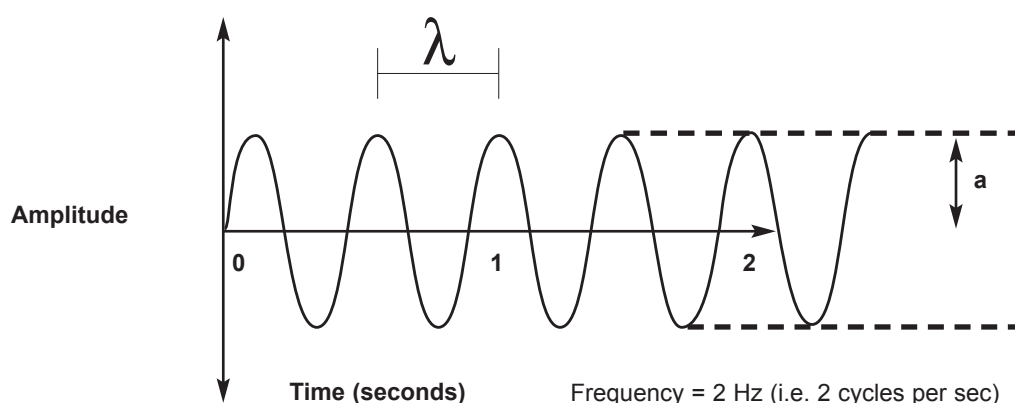

#### SOME DEFINITIONS

<b>Frequency</b>	<b>(f)</b>	the number of complete vibrations or fluctuations each second (i.e. cycles per sec).
<b>Amplitude</b>	<b>(a)</b>	the distance between O on the Amplitude axis and a crest.
<b>Wavelength</b>	<b>(λ)</b>	the distance between any two identical points in a wave (literally the length of one wave).
<b>Velocity</b>	<b>(v)</b>	the speed with which the waves moves is given by the formula: $v = f \lambda$

**Relationship between frequency, wavelength and velocity**

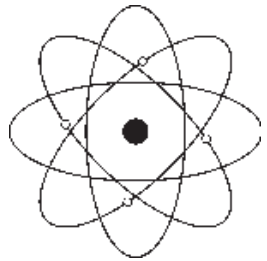
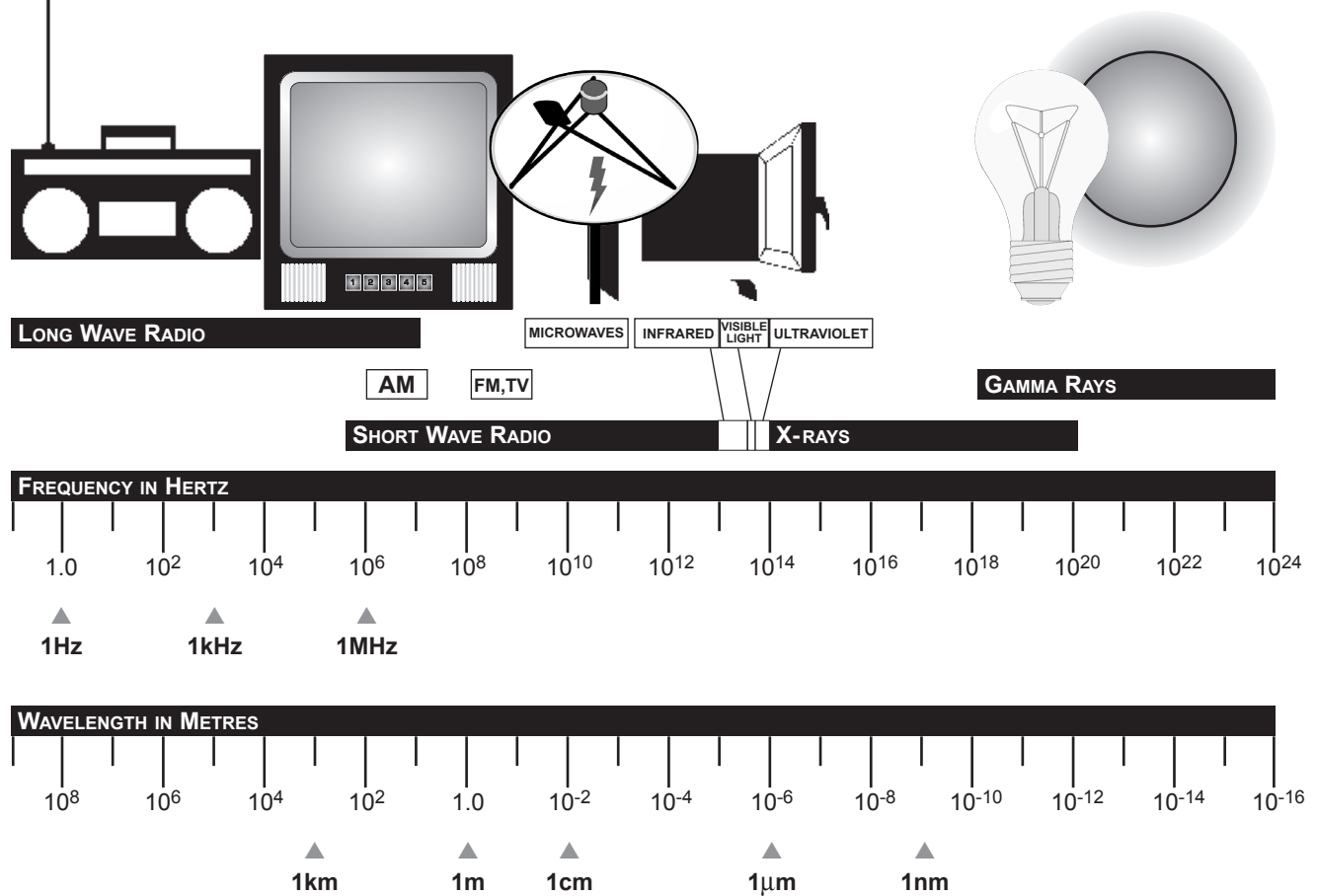

Fig 1-4: Comparative Wavelengths in common usage

Why use electromagnetic energy

9. Using 'em' energy to carry our communications information has many advantages compared with sound energy:

**Advantages of em**

- a. Speed of travel is extremely fast, at the speed of light, it is always  $3 \times 10^8$  metres/second (sometimes expressed as "ms<sup>-1</sup>"), which is 186,000 miles/second.
- b. 'Em' waves will travel through a vacuum and so can be used for communication in space.
- c. 'Em' waves travel a long way for a given power rating.



### Why use such high frequencies?

#### ***Wavelength affects efficient aerial length***

10. Aerials used for transmission or reception operate best at certain wavelengths. The length of the aerial dictates the frequency at which it will transmit and receive most readily, and aerial lengths of  $\lambda/2$  for horizontal polarisation and  $\lambda/4$  for vertical polarisation are particularly efficient. As we know the velocity of the waves and, if given the frequency, we can calculate the wavelength and the best aerial lengths for that frequency. The wavelength is calculated by dividing the velocity of the wave by its frequency.

---

$$\lambda = \frac{v}{f}$$

When  $f$  is the frequency,  $v$  is the velocity ( $3 \times 10^8$  metres/second) and  $\lambda$  is the wavelength.

Example:

What horizontally polarised aerial length would suit a frequency of 200KHz?

$$\lambda = \frac{3 \times 10^8}{200 \times 10^3}$$

$$\lambda = 1.5 \times 10^3$$

$$\lambda = 1500 \text{ metres}$$

**Therefore an aerial length of 750 metres is required for best results.**

Notice – the higher the frequency, the shorter the aerial required.

What does this tell us about the operating frequency of a car-mounted CB compared to a hand held mobile phone?

#### ***Marconi's first message in 1901***

### Radio

11. In 1901 the Italian engineer and physicist Gulielmo Marconi was the first man to transmit and receive transatlantic radio signals. The radio waves were sent in groups of short and long signals by switching the transmitter “OFF” and “ON” – Morse code. Although effective, this system did depend on the operators learning Morse code – not something everybody could do. For a system that everyone could use, some way of making the radio waves to carry more information had to be found.

12. 'Em' energy can be made to carry speech if we combine the low-frequency currents produced by speaking into a microphone, with the high-frequency currents that produce radio waves. This combination process is called modulation.

Modulation

*Combining high and low frequencies – modulation*

13. For the transmission of sounds such as speech and music, the sound waves are converted by a microphone into an oscillating electric current which varies at the same frequency as the sound wave. This is called an "audio-frequency" current.

*Oscillator provides RF*

14. An electronic circuit called an oscillator produces a continuous high-frequency (radio frequency) current which has a fixed frequency chosen from the range 100 KHz to 1 GHz. This fixed-frequency alternating current produces the 'em' "carrier" wave. The audio-frequency (AF) current and the radio-frequency (RF) current are mixed in the transmitter so that the carrier wave is MODULATED by the AF current, in such a way as to duplicate the pattern of sound waves fed into the microphone. A carrier wave can be modulated in one of two ways, either by amplitude modulation (AM) or by frequency modulation (FM).

Amplitude Modulation (AM)

*AM*

15. The simplest form of amplitude modulation (AM) is basically the way Marconi sent his first transatlantic message. The transmitter is switched alternately "ON" and "OFF" to interrupt the carrier wave. This modulates the amplitude from maximum to zero, and then back to maximum, producing pulses which represent the dots and dashes of the Morse Code.

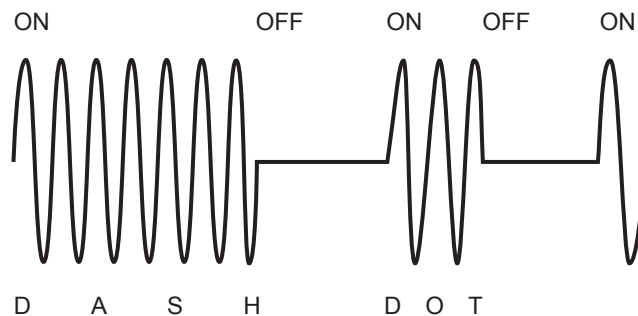

*Fig 1-5: Amplitude Modulated carrier wave*

16. Whilst this system is ideal for Morse, it is not good enough for speech or music, because sound requires many more variations (or steps) to achieve an accurate reproduction. An improvement is to alter the amplitude of the high-frequency tone (the carrier wave) in step with the lower frequency audio tone.

**Fig 1-6:** Carrier wave plus AM wave form



### Basic AM Transmitter

17. The diagram (Fig 1-7) shows the various stages of a simple AM transmitter.

**Fig 1-7:** AM transmitter block diagram

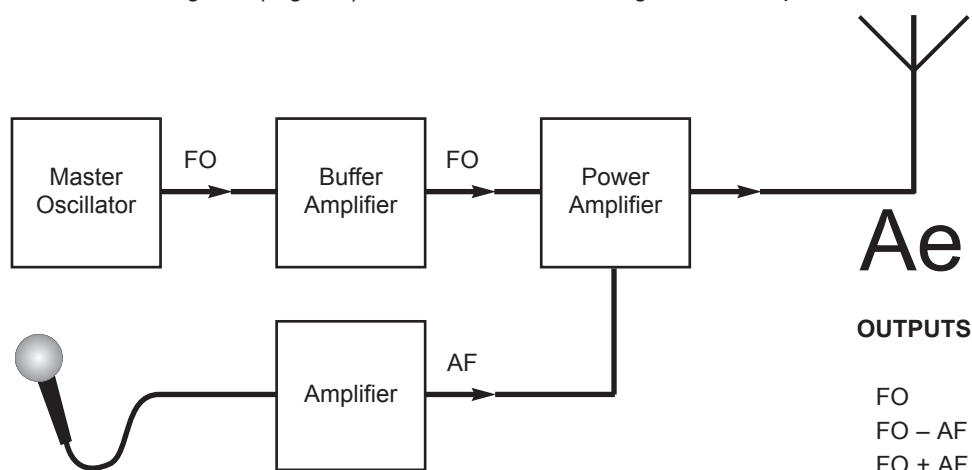

#### **Parts of the basic transmitter**

- a Master Oscillator. This generates a sinusoidal voltage (the carrier) at the required RF frequency (FO ). Oscillators are often crystal-controlled to ensure good frequency stability.
- b Buffer Amplifier. This isolates the oscillator from the power amplifying stage, and prevents instability occurring.
- c Power Amplifier. This is used to increase the power of the signal to the required level before radiation from the aerial (AF).
- d Amplifier. This amplifies the microphone signal to the desired level for output.

18. The modulation takes place in the power amplifier stage. If the input frequencies to the modulator are FO from the oscillator and AF from the microphone, we find that the output of the power amplifier will consist of 3 frequencies:

- a. The carrier (FO ).
- b. The carrier minus the tone frequency (speech) (FO – AF).
- c. The carrier plus the tone frequency (FO + AF).

19. For example, if the audio frequency ranged from 300 to 3000 Hz and the carrier was 1 MHz, then the frequencies in the output would look like:

**Fig 1-8: Carrier and sidebands**

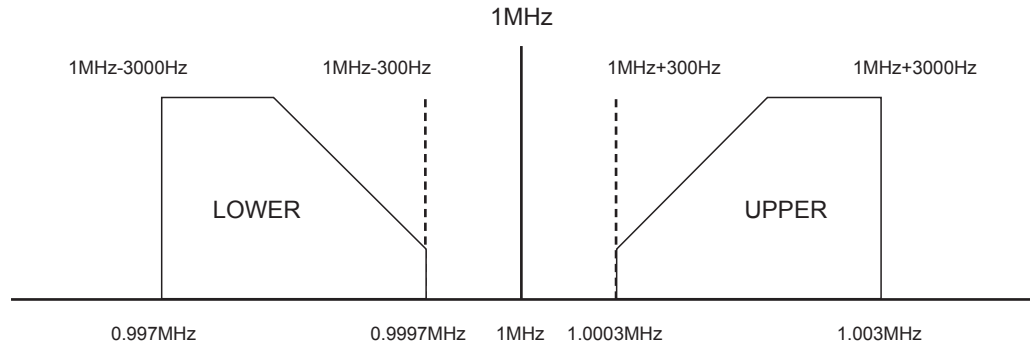

20. In the diagram you can see two sidebands to the carrier frequency, an upper sideband and a lower sideband. Some modes of operation use only one, and this is called single sideband (SSB) transmission. Transmitting only one sideband reduces the size and weight of the transmitter – important factors when talking about aircraft systems. The great drawback with the AM system is the need for such a large bandwidth (i.e. all frequencies including both sidebands, approximately 6KHz) in a limited frequency spread (30 KHz to 3 MHz i.e. Medium band). This means in reality that the AM system could only have 148 stations at any one time. Try tuning through an AM band radio and see how close the stations are together! Obviously, when many transmitters are crammed into a small band and overlap each other there is a big problem with signals from other transmissions breaking into the one you are using – this is known as "interference". To overcome this, the use of short-range frequency modulated systems has become popular.

Frequency Modulation (FM)

**FM – high quality broadcasts**

21. With frequency modulation, the carrier wave has a constant amplitude and a much higher frequency than AM signals. Modulation is achieved by shifting the carrier frequency up and down slightly in step with the tone frequency. Although this shift is small it gives better results because it is less prone to atmospheric or man-made noise. Try listening to an AM signal as you pass by an electric pylon or enter a tunnel. The AM signal is distorted or lost, but an FM signal will be largely unaffected by the same conditions. FM is used in the range 88-108 MHz for high quality broadcasting; this frequency range is within a band known as the Very High Frequency (VHF) band.

**Fig 1-9:** Comparison between AM and FM signals

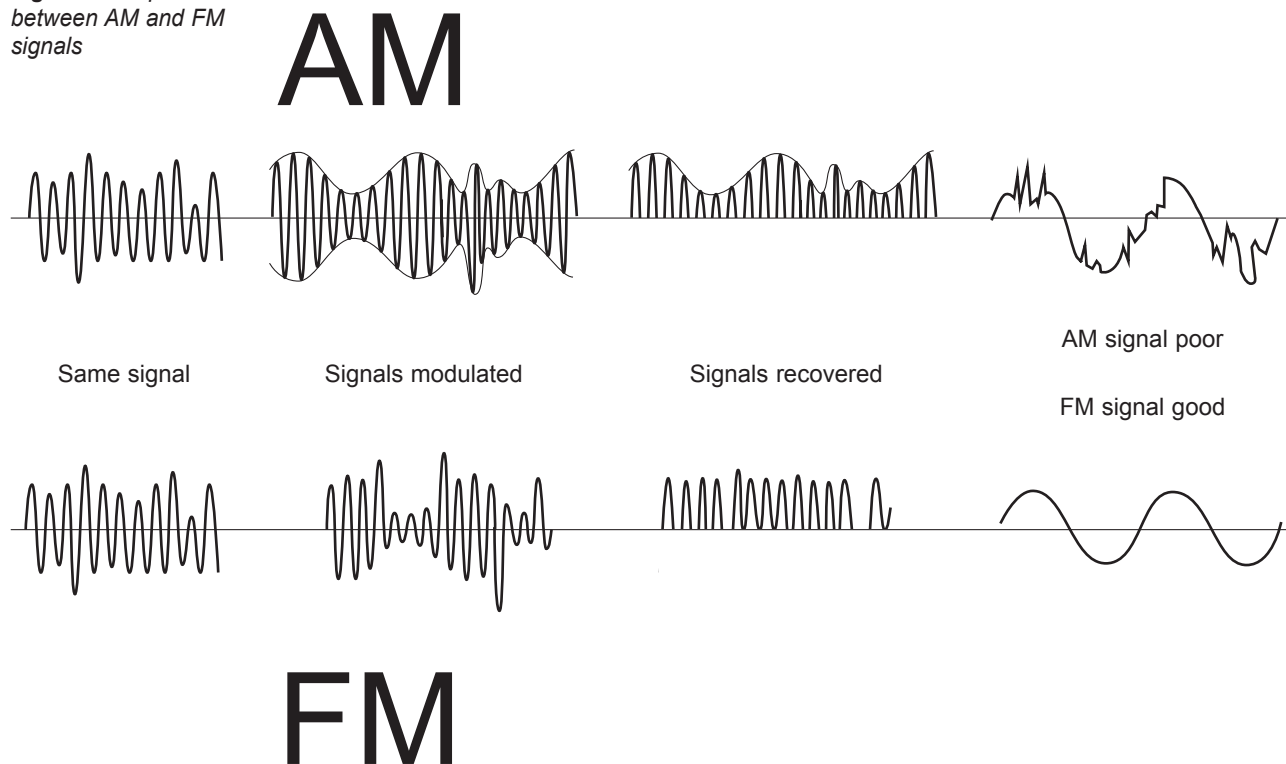

Self Assessment Questions

*Do not mark this page  
in any way! Write your  
answers on a separate  
piece of paper*

1. What is the speed of light ?
  - a.  $3 \times 10^8 \text{ ms}^{-1}$
  - b.  $3 \times 10^6 \text{ ms}^{-1}$
  - c.  $30 \times 10^9 \text{ ms}^{-1}$
  - d.  $30 \times 10^1 \text{ ms}^{-1}$
  
2. The relationship between frequency (f), wavelength ( $\lambda$ ) and velocity of light (v) is given in the formula:
  - a. velocity = frequency x wavelength ( $v = f \times \lambda$ )
  - b. velocity = frequency + wavelength ( $v = f + \lambda$ )
  - c. velocity = frequency - wavelength ( $v = f - \lambda$ )
  - d. frequency = velocity - wavelength ( $f = v - \lambda$ )
  
3. If the velocity of radio waves is  $3 \times 10^8$ , what would be the value of  $\lambda$  for a frequency of  $3 \times 10^6$  ?
  - a. 1000m
  - b. 10m
  - c. 100m
  - d. 1m
  
4. What does the abbreviation SSB stand for ?
  - a. Single Side Band
  - b. Single Silicone Band
  - c. Ship to Shore Broadcast
  - d. Solo Side Band